

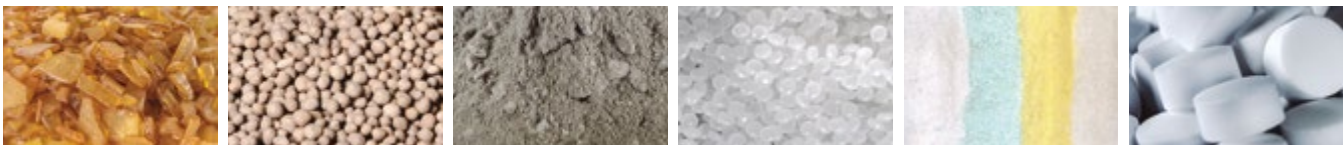

FORM FILL & SEAL BAGGING TECHNOLOGY

ASSAC

FORM FILL & SEAL
BAGGING TECHNOLOGY



BAGGING AND PALLETIZING

Worldwide supplier of bagging solutions



FFS AUTOMATIC BAGGING MACHINES MODELS ASSAC

The **ASSAC Models** bagging machines are designed to work with tubular roll films. The **FFS concept Form, Fill & Seal** means that all these functions, forming filling and sealing the bags, are executed within the same compact machine.



This concept is very reliable, due to the fact that bags are held during the whole process and only released once the entire process is finalized.

ASSAC S10/15



400 bags/hour

ASSAC S-10/15 are the gross weight version of the ASSAC models designed for low output capacity up to 400b/h or for products difficult to handle such as powdery and fragile products. It is also a perfect solution for projects where there is insufficient space in terms of height.

ASSAC L10



1 500 bags/hour

ASSAC L-10 is a medium output capacity bagging machine reaching up to 1500b/h. It is also designed to handle free flowing products such as fertilizers and all type of plastic pellets. (HDPE LDPE, PP,...)

ASSAC F10



2 000 bags/hour

ASSAC F-10 is a high output capacity bagging machine reaching up to 2000b/h. It is designed to handle free flowing products such as fertilizers and all type of plastic pellets. (HDPE LDPE, PP,...)

ASSAC MODELS FEATURES

ASSAC		S10	S15	L10 ≤1200b/h	L10 1200 - 1500 b/h	F10
	Max Output	400	300	1200	1200-1500	2000
	Installed Power kW	15	15	15	15	18,5
	Pneumatic consuption Nm ³ /h	18	13,5	50	64	124
TYPICAL APPLICATION	Granulated free flowing	✓	x	✓	✓	✓
	Fine granulate >200µm	✓	x	✓	✓	✓
	Powdery products	x	✓	✓	x	x
BAG TYPE	PE Tubular film, Aluminium PE Laminated	✓	✓	✓	✓	✓
	Bag length (Filled)	425 - 775 mm				
	Bag width	240 - 440 mm				
	w/o Gussets	Optional				
	Filling weigths	5 - 50 kg				
WEIGHING SYSTEM	Net weight configuration	x	x	✓	✓	✓
	Gross weight configuration	✓	✓	x	x	x

✓ Yes x No

DOSING SYSTEM

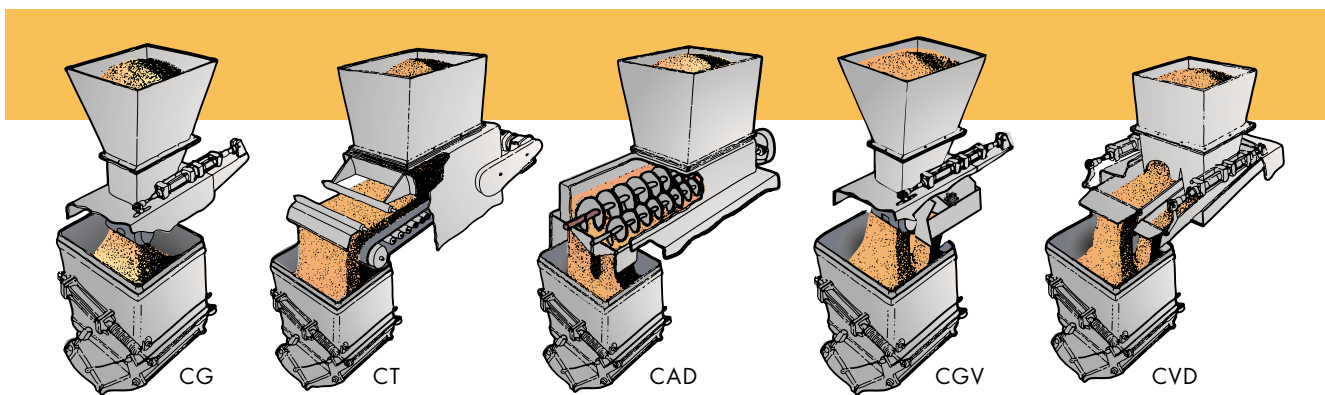

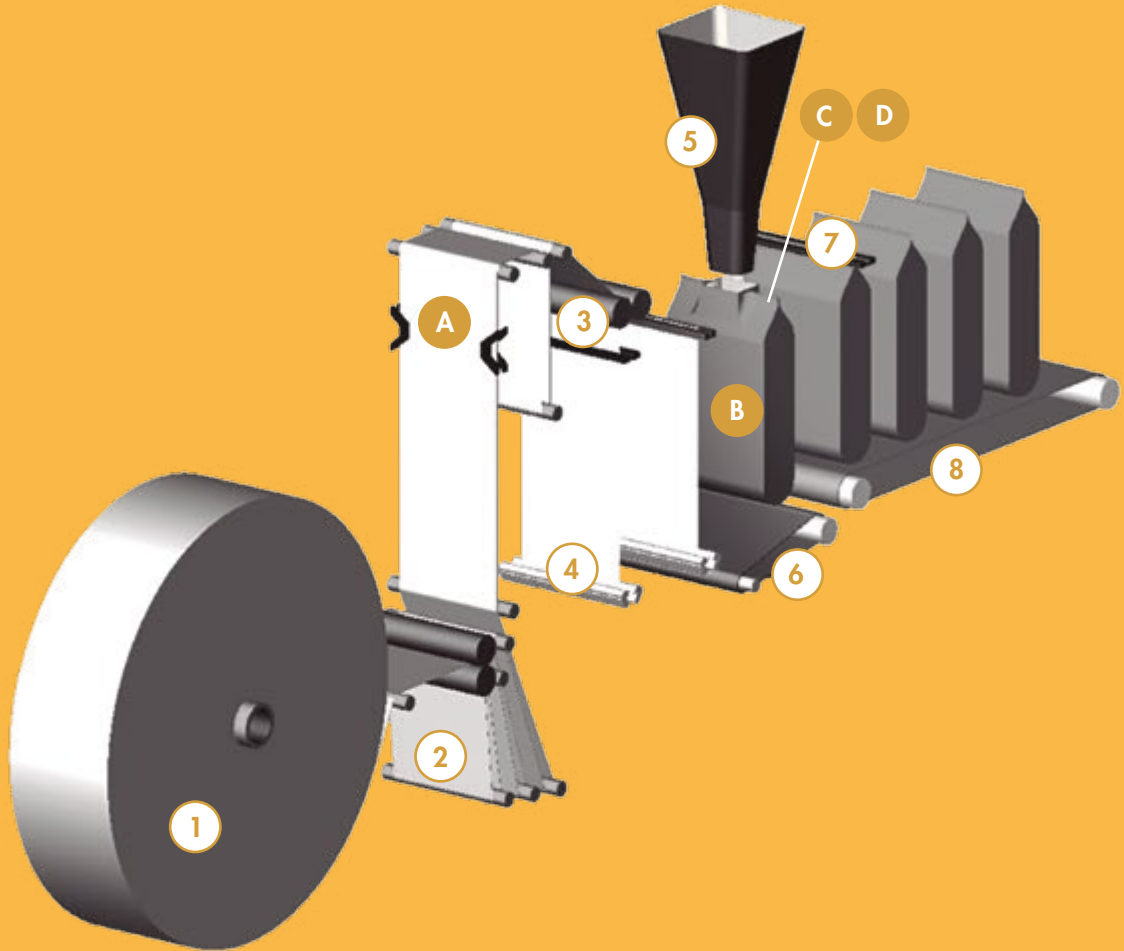

STANDARD CONFIGURATION

- ① Film unwinding station.
- ② Film accumulator.
- ③ Bag forming station (cutting and lower welding)
- ④ Bag bottom cooling station.
- ⑤ Bag filling station.
- ⑥ Bottom compacting system.
- ⑦ Bag sealing and bag cooling station.
- ⑧ Bag exit belt.

OPTIONAL FEATURES

- Ⓐ Bag corner sealing configurable system.
- Ⓑ Bag bottom filling system.
- Ⓒ Dearation probe for residual air.
- Ⓓ Airwash bag top cleaner.

APPLICATIONS ASSAC

All types of products. From very powdery to granules.



AGRO-FOOD
INDUSTRY



BUILDING
INDUSTRY



CHEMICAL
INDUSTRY



PETROCHEMICAL
INDUSTRY



**ALL THESE PRODUCTS AND MUCH MORE CAN BE
PACKED WITH OUR ASSAC FFS TECHNOLOGY!**



CLEANABLE

Bagging lines designed for easy cleaning in order to avoid bacteriological and cross-contamination.



ATEX

Upon customer request equipment can be manufactured and certified in order to be installed in classified ATEX area.



ANTI CORROSION

Different types of protection against corrosion are available, in accordance to the aggressivity of the product and the environment.



BOTTOM FILING

Option which allows product discharge starting from the bottom of the bag, avoiding dust emission and product segregation.

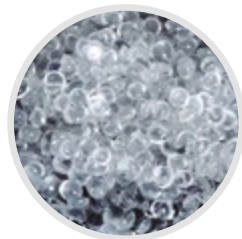

HIGH CAPACITY

Special configuration bagging machines designed for projects with high capacity outputs.



OPTIONAL FEATURES

FOR CORROSIVE PRODUCTS

Various levels of protection are available such as different quality of the Stainless steel, heating systems, electric and pneumatic components housed, connectionless detectors...etc.



FOR DUSTY PRODUCTS

Special design has been created in order to avoid dust emissions featuring a airtight bagging spout and bottom filling system. This special design also prevents product segregation.

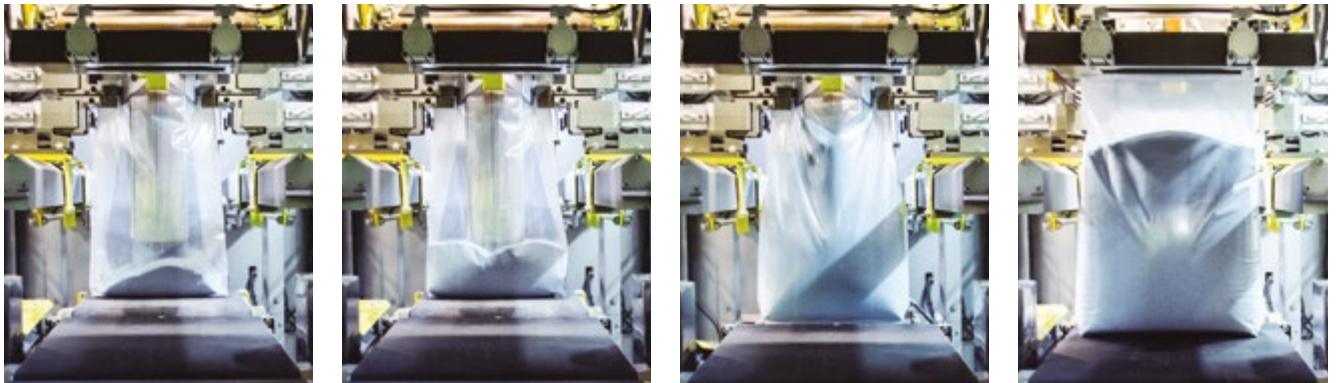

FOR CLASSIFIED AREA / ATEX ZONE

Adapted machine configuration allows installing the machine in a classified ATEX area in accordance to the relevant zone level and the product explosion risk.



CORNER SEALING SYSTEM

Option created in order to obtain a brick shaped bags for better palletizing, better over wrapping and better bag emptying.

MOVABLE PLATFORM

If needed the complete bagging installation could be mounted on a moving platform so that it could easily maneuver underneath different silo positions.

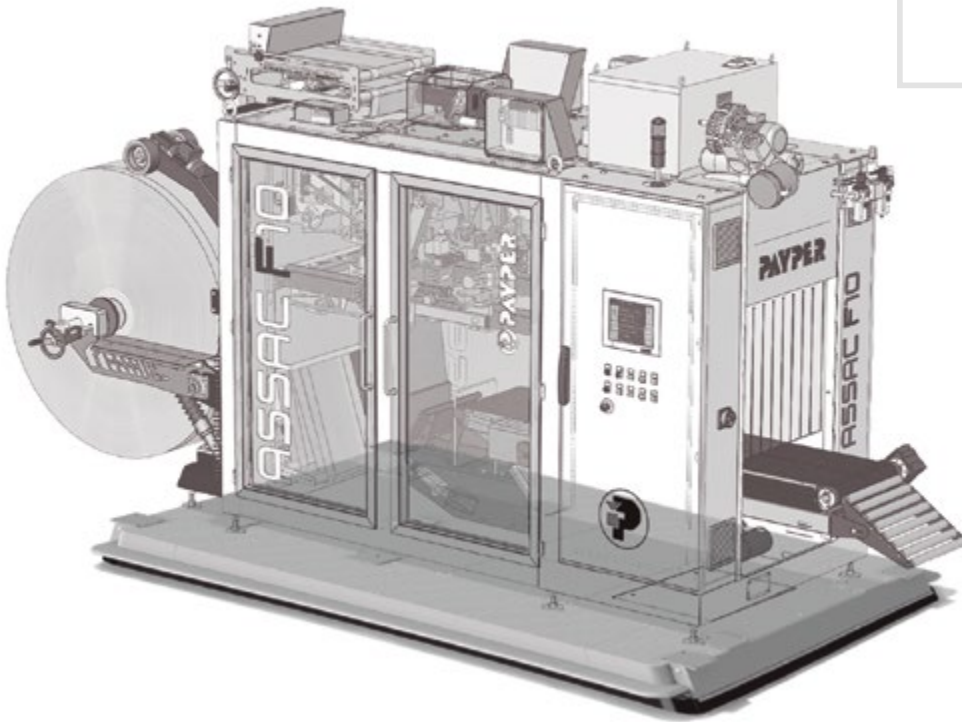

MAIN REFERENCES





Permanent investment in
research and development



Worldwide Technical Service

Pol. Ind. El Segre, par. 115
25191 LLEIDA - SPAIN
Tel. +34 973 216 040 | Fax +34 973 205 893
info@payper.com

www.payper.com



SPAIN · FRANCE · MEXICO · BRAZIL · INDIA

